

New Scale Technologies

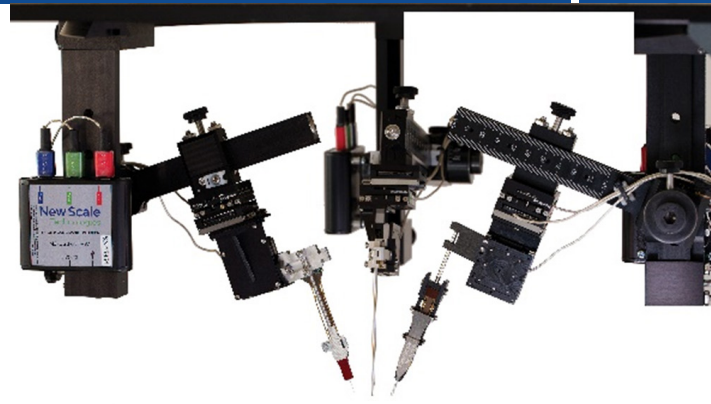

MPM

Multi-Probe Micromanipulator System

Accelerate discovery in acute *in-vivo* neural recordings

- Automatically position multiple probes with maximum precision and density
- Use Pathfinder Software with Virtual Coordinate System (VCS) to streamline simulation, planning and execution
- **NEW!** Interface with open-source trajectory planning and DAQ apps
- Space-optimized, upright or inverted
- Compatible with probes from imec Neuropixels, NeuroNexus, Cambridge Neurotech and more

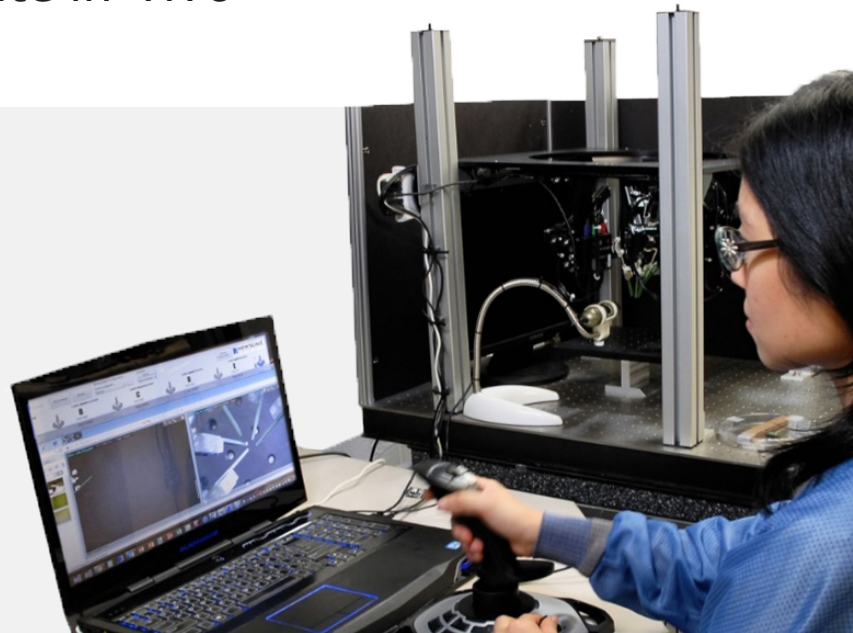

Created with Scientists, for Scientists

The Multi-Probe Micromanipulator (MPM) System provides convenient, automated positioning of multiple neural probes for acute *in-vivo* recording. Simple to set up and operate, it is the first micro-manipulator **designed specifically for use with silicon probes**.

The compact design allows independent positioning of multiple probes in the smallest space, with ample clear area for a virtual task environment. Automatically and independently move each probe to the optimum location in the brain using one PC.

Each probe arm has four degrees of freedom for pre-adjustment, and three axes of motorized motion for fine positioning and insertion.

Simulation, Planning and Execution

Pathfinder Software with Virtual Coordinate System (VCS) automatically calculates the approach angle of each probe and moves probes independently using stereotactic coordinates. Use the powerful **simulation mode** to plan experiments from your desktop: visualize probe positions and approach angles, set insertion paths, and check for potential probe interference. Then execute your plans with high repeatability.

NEW! Interface with trajectory planning tools (Trajectory Explorer, Pinpoint) and data acquisition apps (Open Ephys GUI, SpikeGLX, Allego) for more accurate probe placement and more scientifically valuable recordings.

Rapid and Accurate Positioning of Multiple Neural Probes

A mounting ring allows multiple probe arm assemblies to be positioned around the target. The ring sections mount to standard laboratory tables (upright configuration) or the underside of an elevated platform (inverted configuration). The system design maximizes space for animal interaction with a virtual task environment.

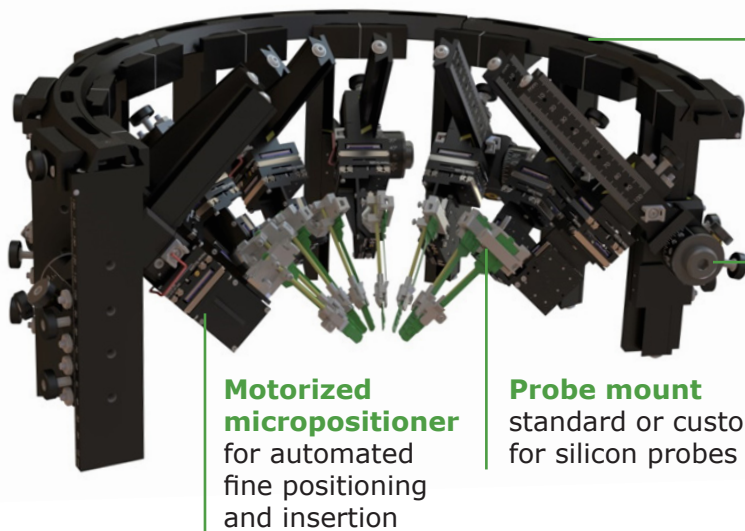

Mounting ring
three ring segments shown, with eight probe arm assemblies

Probe arm assembly
for manual pre-adjustment

Motorized micropositioner
for automated fine positioning and insertion

Probe mount
standard or custom, for silicon probes

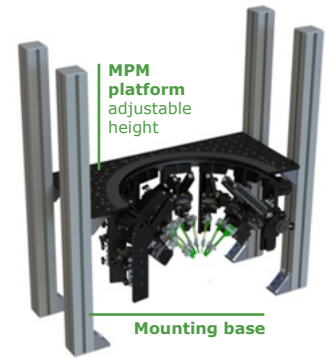

Inverted Configuration

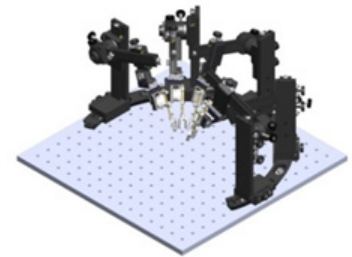

Upright Configuration

Intuitive PC Control Application

A single USB connects all manipulators to a PC. Control up to eight probes from one window using a joystick, mouse or other USB input device. Choose from coarse, fine and insertion step modes. The insertion mode provides very slow z-axis motion while disabling x and y motion.

Pathfinder Software with Virtual Coordinate System (VCS) lets you enter probe angle and displacement, and automatically register each probe to a 2D image or 3D reference space in stereotaxic coordinates. Automatically calculate approach angles and move each probe independently within this global space. You will spend less time calculating angles, more time recording.

Use the powerful simulation mode to plan and visualize probe positions and approach angles, and check for potential probe interference.



Control each probe in stereotaxic coordinates from a gaming controller, joystick, mouse, or other USB device.

A single PC window displays up to five probe controls at once (eight with horizontal scroll). Open additional windows to control more than eight probes, on one or more rigs, using one PC.

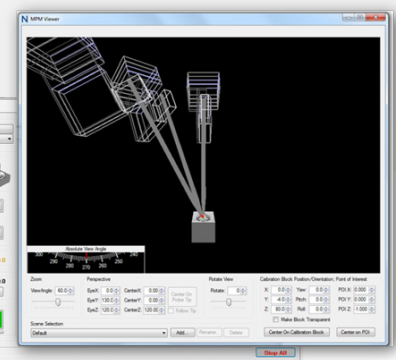
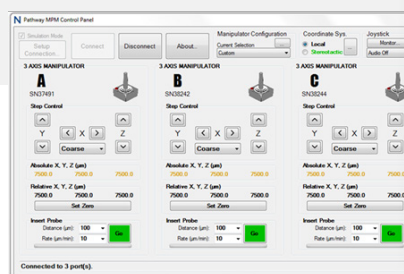

4-DOF Manual Pre-adjustment plus 3-Axis Motorized Positioning

Probe Arm Assembly for Manual Pre-Adjustment (MPM-4 DOF ARM)

The polar angle, arm length, arm height and arm angle are adjustable. Adjustable stops enable repeatable positioning. Displacement markings allow registration of each probe location in stereotaxic coordinates to simplify approach angle calculations.

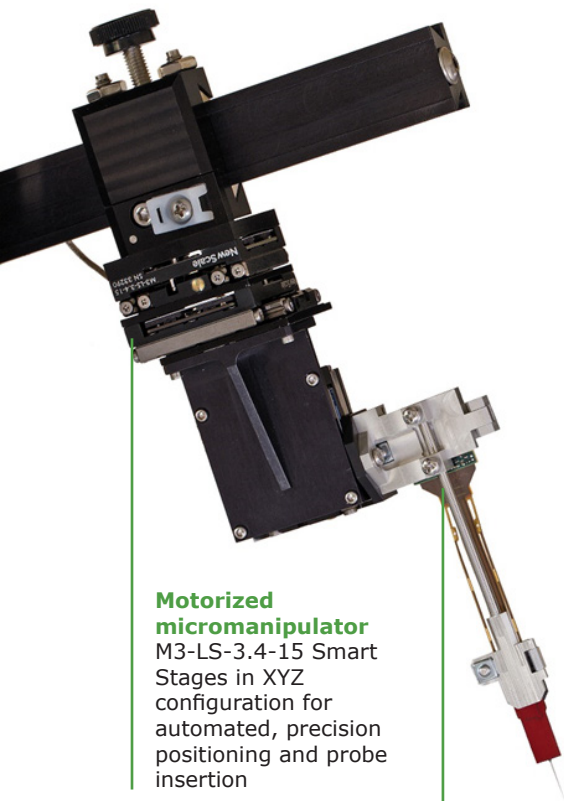
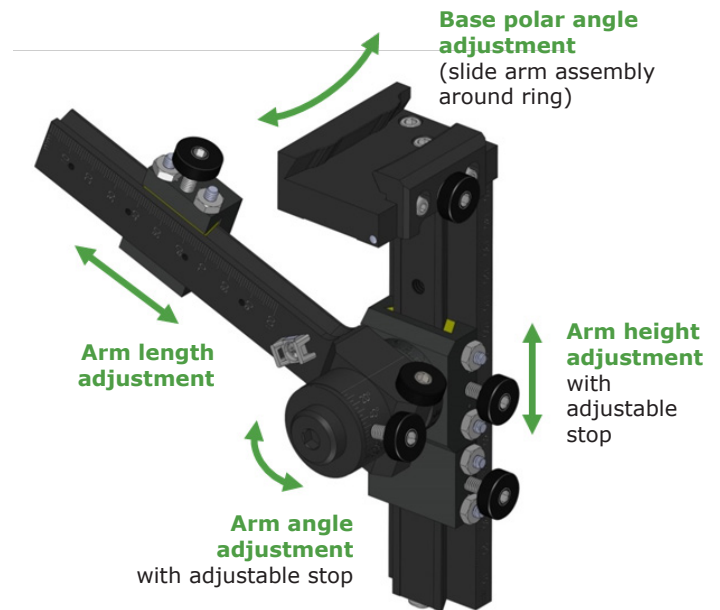

Probe holder
Standard and custom styles for imec Neuropixels, NeuroNexus, Cambridge Neurotech and more

Motorized Micromanipulator for Automated Positioning (M3-LS-3.4-15-XYZ)

A three-axis motorized stage assembly on each arm provides 15 mm of travel along each axis with 0.5 micron closed-loop position resolution. New Scale's M3-LS Linear Smart Stages have embedded SQUIGGLE piezoelectric motors along with all drive and control electronics, eliminating the bulk of separate controllers. The small, rigid, precise mechanical stages, along with an exceedingly stable mechanical loop from the probe tip to the manipulator, ensure a drift-free manipulator environment.

The three stages on each arm connect to a 3:1 USB adapter using clearly marked connectors.



3:1 USB adapter



Fully Configurable, Fully Integrated

MPM Systems are fully configurable for multiple probe arms, inverted or upright position, and type of probe holders.

Each system is complete and easy to assemble with the tools and hardware provided. All cables and connectors are labeled including standard USB cables to the PC. The MPM software installs on your Windows PC in minutes.

The innovative probe mounting and pre-positioning solution reduces setup time, minimizes risk of damage to silicon probes during setup, and maximizes data collection time.

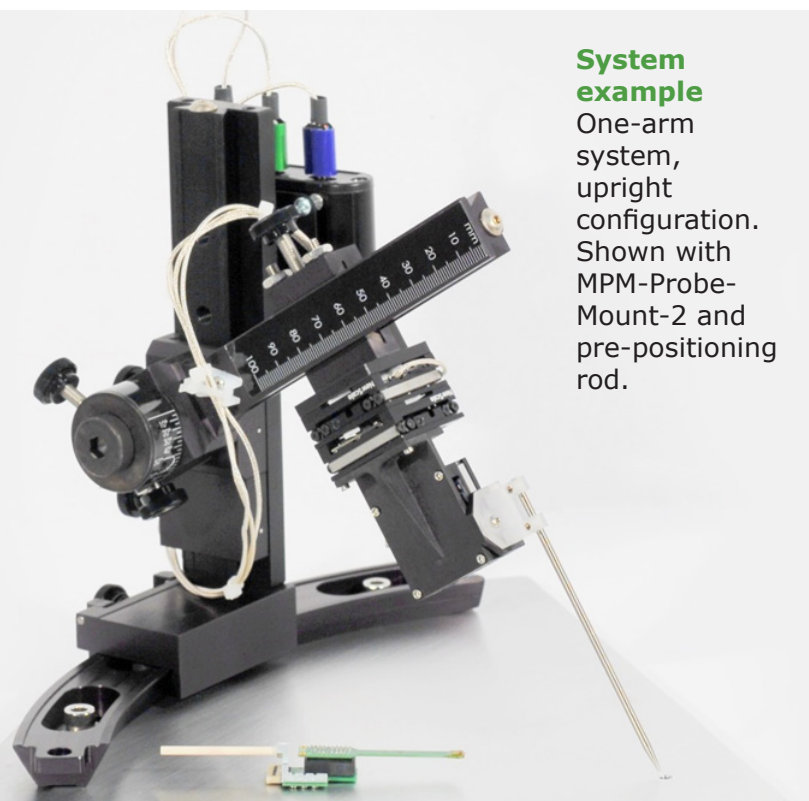

System example
One-arm system, upright configuration. Shown with MPM-Probe-Mount-2 and pre-positioning rod.

Additional information

Visit the website for videos and more information, or call us to configure an integrated MPM system for your research lab.

585.924.4450
NSTsales@newscaletech.com

newscaletech.com

M3-LS-3.4-15-XYZ	
Travel Range (stroke)	15 mm each axis
Payload	100 grams (recommended) 200 grams (maximum)
Linear Slide Features	Crossed roller bearings with highest stiffness
Dimensions	32 x 32 x 11 mm with embedded controller (each axis)
Speed	4 mm/s
Insertion Rate	Adjustable, down to 1 $\mu\text{m}/\text{min}$ 200 $\mu\text{m}/\text{min}$ recommended
Resolution	0.5 μm
Bi-directional Repeatability	< 5 μm
Accuracy	< 20 μm

Components	Description
Items Needed for Each MPM System	
MPM-System Kit	Includes mechanical hardware, instructions, USB Hub, USB cables, and MPM Pathfinder Software with Virtual Coordinate System (VCS).
MPM-Ring-72-DEG	Mounting Ring Section, 72° Arc One per probe recommended. Order five for full 360° positioning flexibility.
MPM-Platform (Optional)	Platform for mounting MPM rings and manipulators in inverted configuration.
Items Needed for Each Probe	
MPM-4 DOF ARM-X	MPM Four-DOF manual positioner Specify inverted or upright configuration <i>X = UPRIGHT or X=INVERTED</i>
M3-LS-3.4-15-XYZ-MPM-X	Three-axis motorized micro-manipulator. Includes: (3) M3-LS-3.4-15 Linear Smart Stages assembled into XYZ configuration (1) M3-USB-3:1 Adapter <i>Specify inverted or upright configuration X = UPRIGHT or X=INVERTED</i>
MPM-Probe Mount-X (Optional)	Mounting bracket and kit for specific probes —contact us for standard and custom options.

New Scale
Technologies